

# WOHS Mathematics Department

Curriculum Night (January-2020)

Emad Abu-Hakmeh

*Supervisor 6 – 12*

Phone: (973) 669-5301 ext. 31543

Email: [eabuhakmeh@westorangeschools.org](mailto:eabuhakmeh@westorangeschools.org)

# *High School Math Requirements*

- Minimum 3 years of Math
- Demonstrate Proficiency in Math. (Next page)
- It is highly recommended that students take 4 years of math.

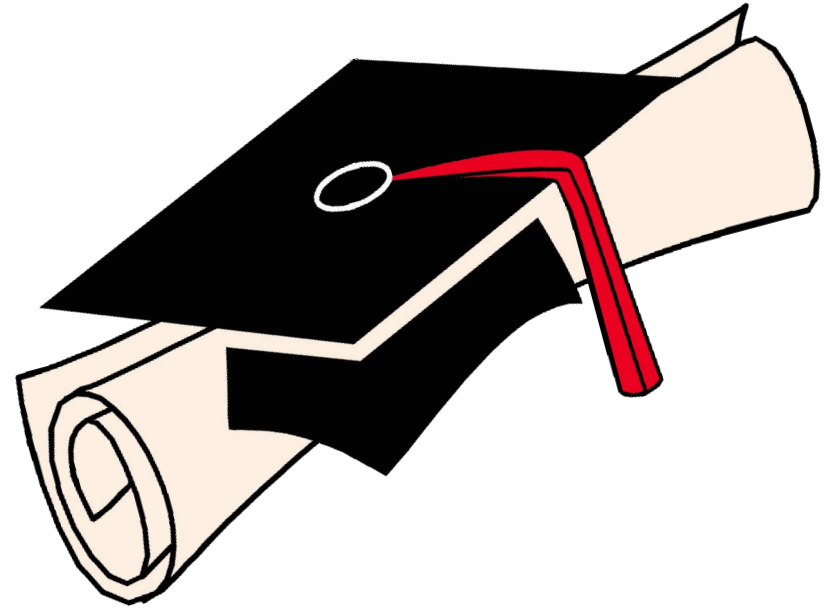

# NJDOE High School Graduation Requirement

## Demonstrating Proficiency in Mathematics

Test	Required Score
PARCC Algebra I	750 or more (Level 4)
PARCC Geometry	725 or more (Level 3)
PARCC Algebra II	725 or more (Level 3)
SAT: (before 3/1/16) / (on or after 3/1/16 or after)	400 / 440
ACT or ACT PLAN	16
Accuplacer Elementary Algebra	76
PSAT10 or PSAT/NMSQT: (before 10/1/15) / (on or after 10/1/15)	40 / 22
ACT Aspire	422
ASVAB-AFQT Composite	31
Meet the Criteria of the NJDOE Portfolio Appeal	Demonstrate alternative classroom work aligned to the common Core State Standards.

# Recent Change

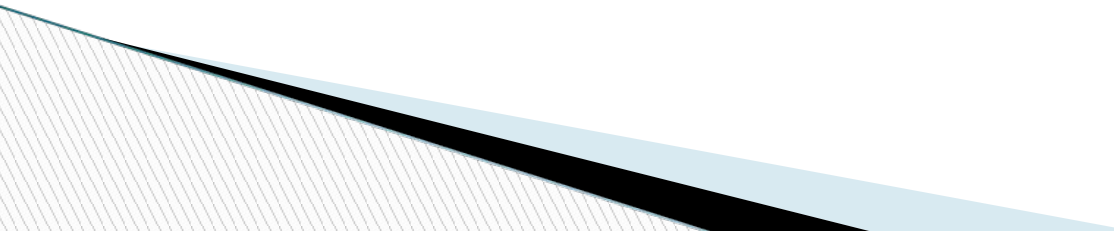
- New Jersey was one of 46 states plus District of Columbia that adopted the Common Core Standards. Recently, New Jersey has shifted to a slightly modified version of the CCSS called New Jersey Student Learning Standards (NJSLS).
  - NJSLS are very much similar to the CCSS
  - West Orange High School began implementation in the 2012 – 2013 school year and will continue to update curriculum to be aligned to the learning standards.
- 

# *The New Jersey Student Learning Standards*

<http://www.state.nj.us/education/cccs/2016/math/standards.pdf>

## ◎ Mission Statement

The **NJSLS** provide a consistent, clear understanding of what students are expected to learn, so teachers and parents know what they need to do to help them. The standards are designed to be robust and relevant to the real world, reflecting the knowledge and skills that our young people need for success in college and careers. With American students fully prepared for the future, our communities will be best positioned to compete successfully in the global economy.

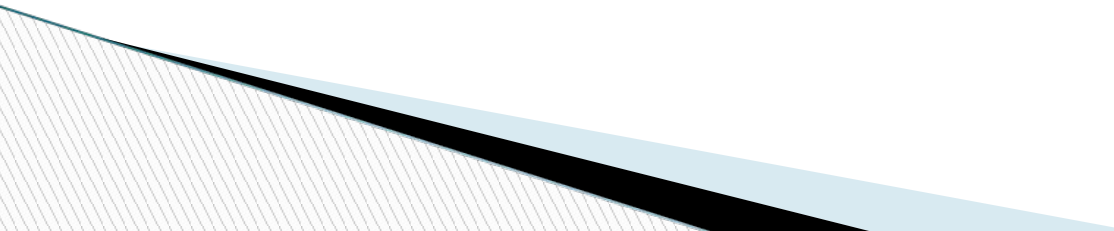

# Mathematics Course Sequence - Class of 2022

Grade 6	Grade 7	Grade 8	Grade 9	Grade 10	Grade 11	Grade 12
---------	---------	---------	---------	----------	----------	----------

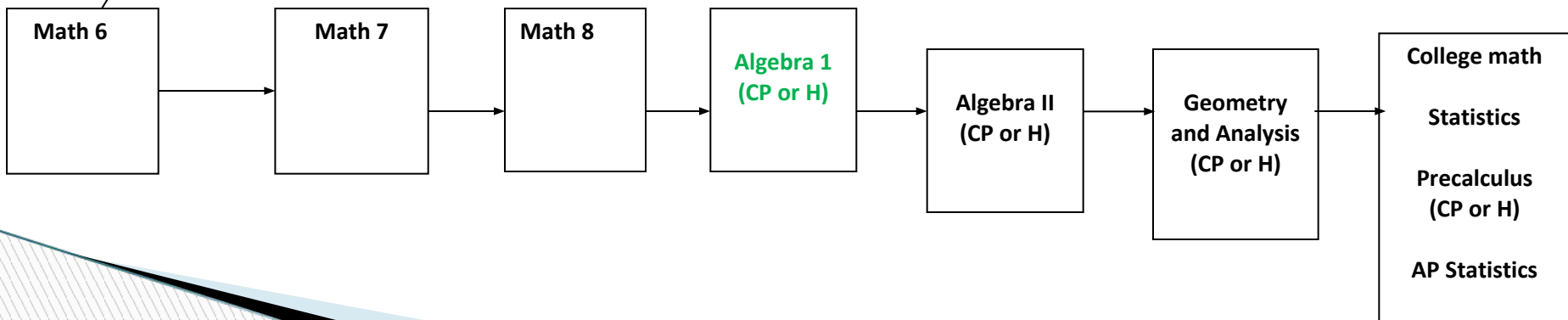
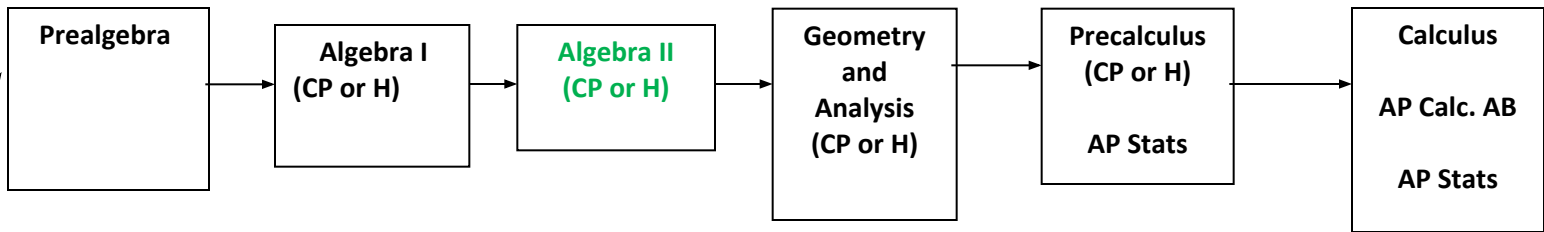
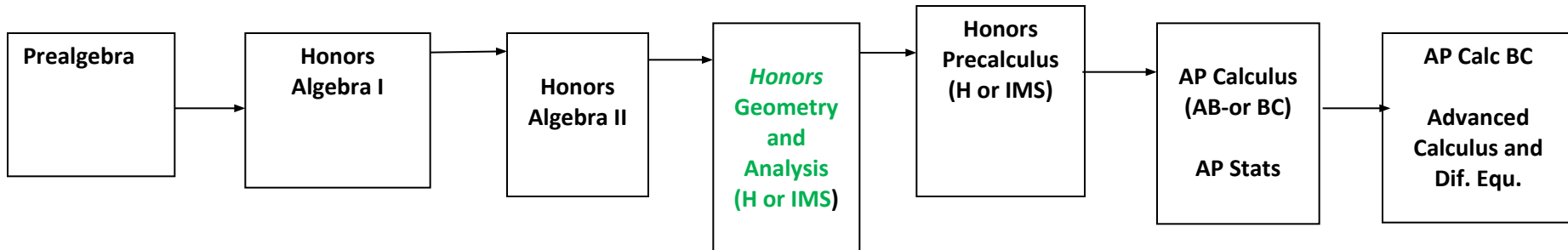

# *Math Opportunities*

## Math Electives

- ◉ Programming in Visual Basic(2.5 Credits )
- ◉ Programming C++ (2.5 Credits)
- ◉ JAVA
- ◉ AP Computer Science
- ◉ Statistics
- ◉ Calculus
- ◉ College math
- ◉ SAT Prep

## Math Extra-Curricular

- ▣ Math Leagues
- ▣ National Math Honor Society (Mu Alpha Theta)

**Teachers available  
Mon – Thurs. for tutoring**

# *How You Can Help:*

- Set the Bar High
  - Research shows that high academic expectations and parental support lead to high student achievement.
- Intervene Early
  - Work with your child's teacher to ensure students are working to their maximum academic abilities.



# ***Thank You for Coming!***

*Any questions, feel free to  
contact me.*

▣ *Emad Abu-Hakmeh*

▣ Phone:

▣ (973) 669-5301 ext. 31543

▣ Email:

▣ [eabuhakmeh@westorangeschools.org](mailto:eabuhakmeh@westorangeschools.org)